

CONFLICT MANAGEMENT AND CLASH DETECTION USING BUILDING INFORMATION MODELLING

Presented by:

Engr. KISHWAR NAZ

Manager

Engineering Support Services
(Arabtec Pakistan Pvt. Ltd)

Presented at:

6th International Civil Engineering Congress
28th December, 2013

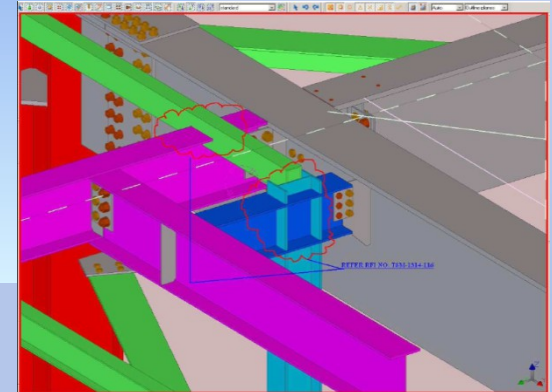
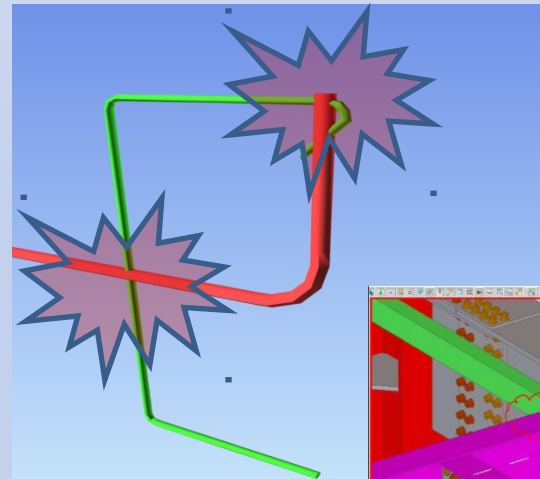

A Collaborative Research Effort

between

NED University

AAA Partnership

with **3D Detailing Expertise (BIM)** by

Arabtec Pakistan Pvt. Ltd

Collaborators

Prof. Rizwan U. Farooqui

Professor and Co-Chair
Department of Civil Engineering
NED University of Engineering and Technology

Mr. Muhammad Ali

Resident Engineer
Bahria Town Icon
AAA Partnership

Miss Kishwar Naz

Manager Engineering Support Services
Arabtec Pakistan Pvt. Ltd.

Spectrum of Presentation

- **Introduction to Building Information Modeling-(BIM)**
- **BIM Transformation**
 - Physical & Virtual Modeling
- **Tools for BIM**
- **Benefits of BIM**
- **Technical Edge using BIM**
- **BIM Services**
- **Case Study Introduction, Importance & Significance**
- **Model Generation**
 - Data Collection
 - Software Used
 - Architecture Model
 - Reinforced Model
- **Model Analysis & Results**
 - Clash Detection
 - Conflict Management
 - Conclusion

Introduction to BIM

- **Building** - the entire lifecycle is considered i.e. design, build & operations
- **Information** – Includes all relevant data about the building and its lifecycle
- **Modeling** - defining and simulating the building, its delivery, and operation using integrated tools
 - Developments in the Structural architecture, engineering, and construction industry.
 - Increase the construction productivity, better constructability, time and cost saving technique.
 - Support a distributed team so that people, tools, and tasks can effectively share this information.
 - Eliminate
 - Data redundancy.
 - Data re-entry, data loss.
 - Miscommunication.
 - Translation errors.

The National BIM Standard (NBIMS) defines BIM as.....

- A digital representation of physical and functional characteristics of a facility. As such, it serves as a shared knowledge resource for information about a facility forming a reliable basis for decisions during its life-cycle.

(National BIM Standard, 2012)

BIM Transformation

BIM actually transformation from 2D to 3D

2D drawings sufficient for most of the simple projects but for mega / Complex projects, Architects engineers would resort to physical models made out of wood, clay, or other appropriate materials to demonstrate aesthetic aspects of the structure. Expensive, far from perfect and often times of limited practical utility, especially for capturing design details.

Physical vs Virtual



Tools for BIM

- Auto Cad, Navisworks – Non BIM Software
- Tekla Structures, Rivet – BIM Applications

Benefits Of BIM (Across Organization)

- **Owners**—High level summary information about their facilities
- **Planners**—Existing information about physical site(s) and corporate program needs
- **Realtors**—Information about a site or facility to support purchase or sale
- **Appraisers**—Information about the facility to support valuation
- **Mortgage Bankers**—Information about demographics, corporations, and viability
- **Designers**—Planning and site information

Benefits Of BIM (Across Organization)

- **CIO's**—Basis for better business decisions and information about existing infrastructure
- **Risk Management**—Better understanding of potential risks and how to avoid on minimize
- **Occupant Support**—Visualization of facility for finding places - people can't read floor plans
- **First Responders**—Minimize loss of life and property with timely and accurate information

Technical Edge using BIM

- **Engineers**—Electronic model from which to import into design and analysis
- **Cost & Quantity Estimators**—Electronic model to obtain accurate quantities
- **Specifier**—Intelligent objects from which to specify and link to later phases
- **Contracts & Lawyers**—More accurate legal descriptions as well as more accurate to defend or on which to base litigation
- **Construction Contractors**—Intelligent objects for bidding and ordering and a place to store gained information
- **Sub-Contractors**—Clearer communication and same support for contractors

Fundamental Concept of BIM

Most of the important benefits of BIM can be tied to three fundamental concepts:

- **Database Instead of Drawings**
- **Distributed Model**
- **Tools +Process=Value of BIM**

BIM Application On

Real Life Projects / Modeling
Highlights

CASE STUDY

INTRODUCTION

Bahria Town Icon is a skyscraper under construction in Karachi, Pakistan which is the tallest building project in all over Pakistan.

The structure has been designed with seven basement parking floors, split upper and lower ground floors and 59 office tower floors.



CASE STUDY

SIGNIFICANCE

Bahria Town Icon (BTI) was chosen as the subject for the case study and primary reasons behind it were:

- Complexity and Individuality of this project
- Unique Structural elements used/provided
- Selected 24th floor was in between design and execution stage (planning stage) which provides best opportunity to apply BIM



MODEL GENERATION



DATA COLLECTION:

- Initially 2D CAD Drawings of 24th floor were collected from AAA Partnership (PVT) Ltd
- DWG Drawings included Slab, Beams, Columns, Exterior Walls and Outriggers Profiles and Sections
- Thorough review of drawings and meetings with external supervisor was conducted to gain understanding of the model to be generated

MODEL GENERATION

SOFTWARE USED:

- Architectural Model: Autodesk AutoCAD & Autodesk Revit
- Structural Model: Autodesk AutoCAD & TEKLA Structures
- Analysis: Autodesk Navisworks



MODEL GENERATION

Software Training & 3D Detailing Concepts

- Assistance & Training for the Architectural & Structural Modeling was given by **Arabtec Pakistan (PVT) Ltd**
- Design Drawing Assistance was given by **AAA Partnership (PVT) Ltd**



MODEL GENERATION

- ARCHITECTURAL MODEL

- Mass model for the 24th floor which includes its Beams, Slabs, Columns, External Walls, Core Walls and Outriggers were developed as per design.

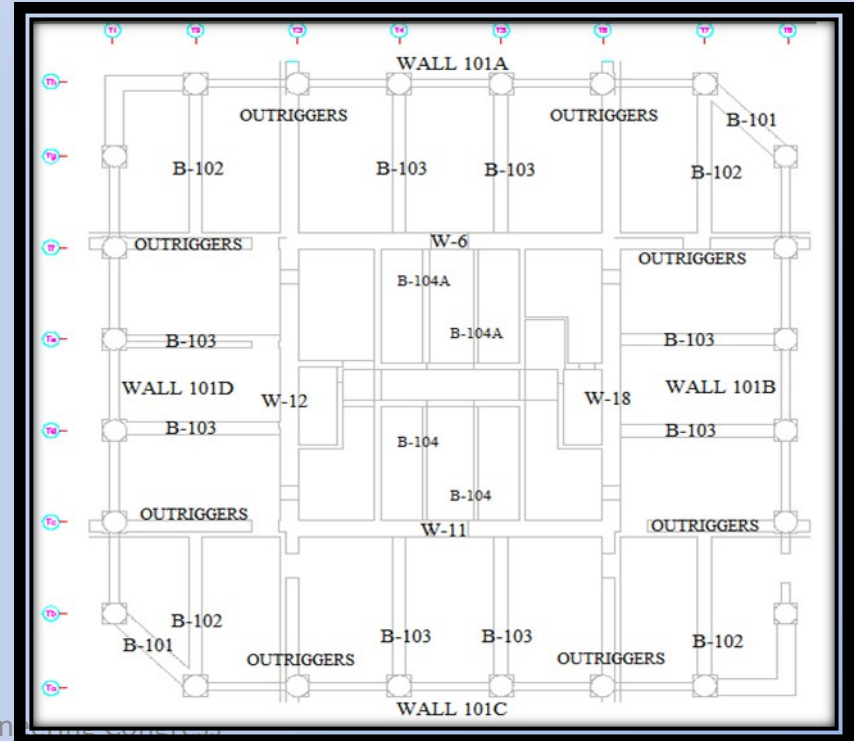
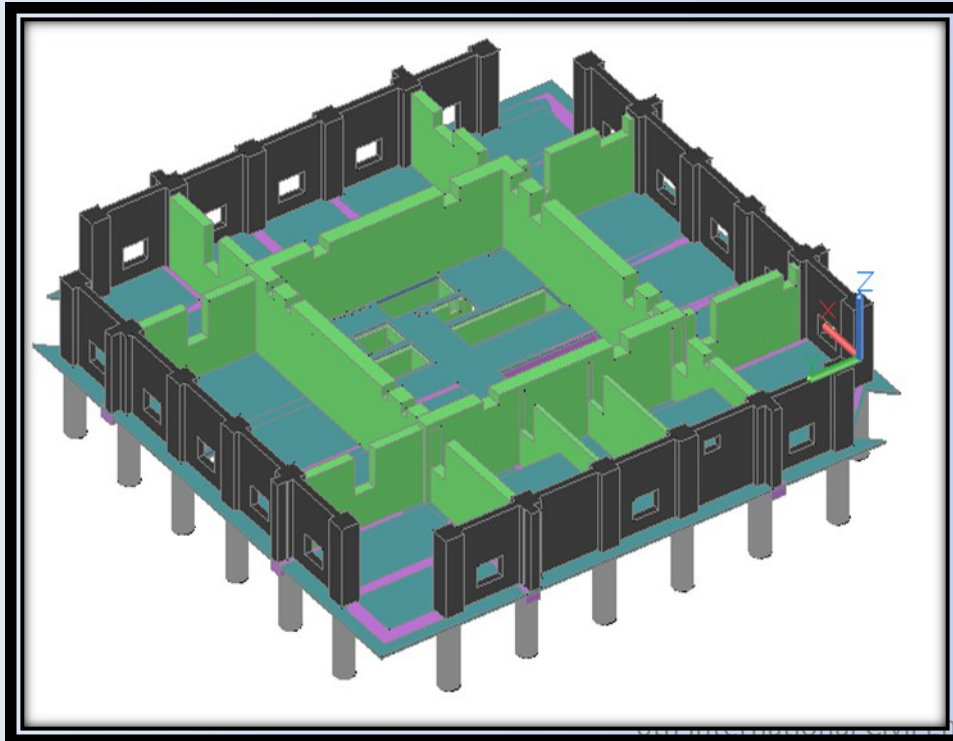

MODEL GENERATION

- ARCHITECTURAL MODEL

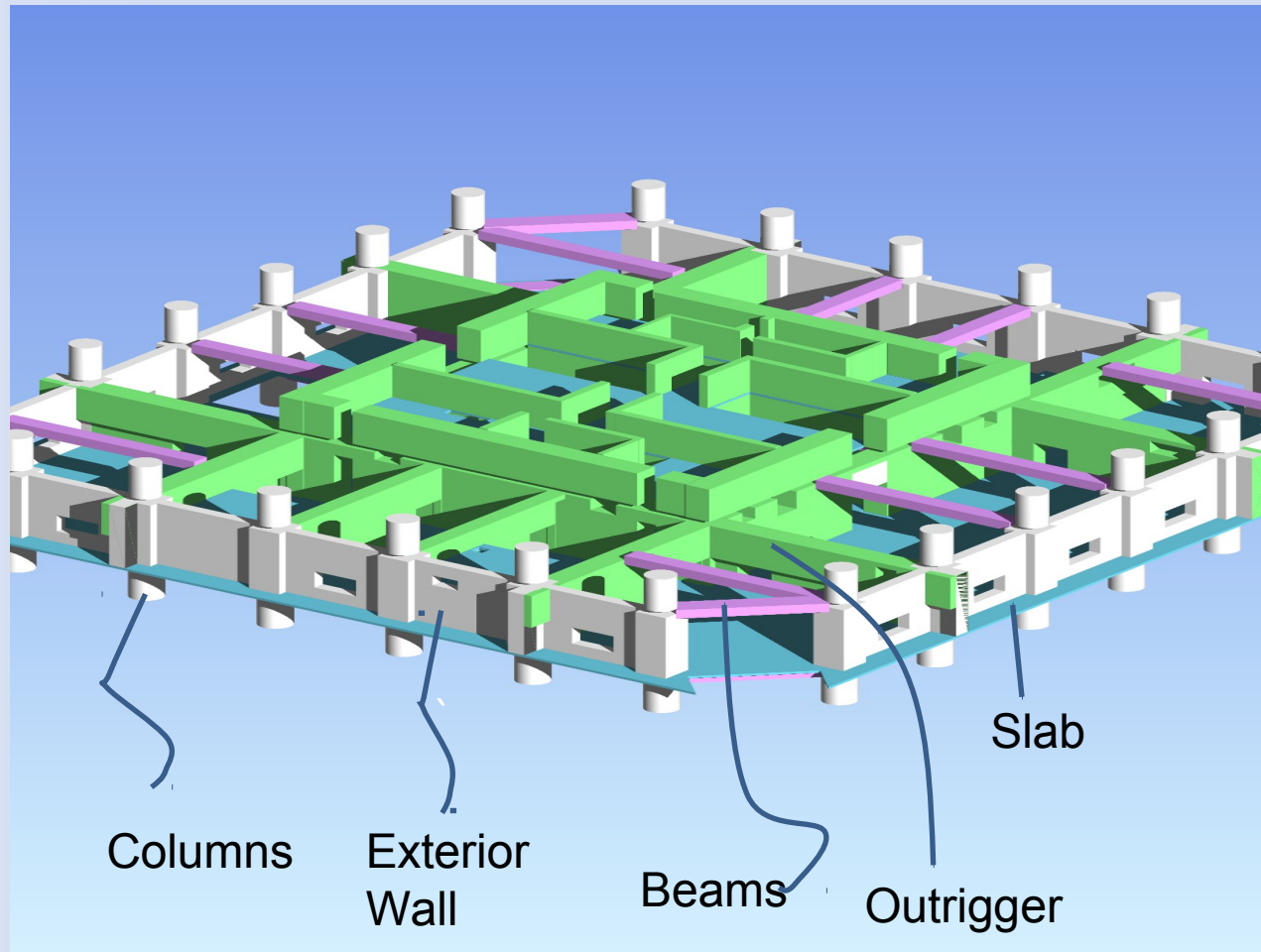

MODEL GENERATION

- REINFORCEMENT MODEL

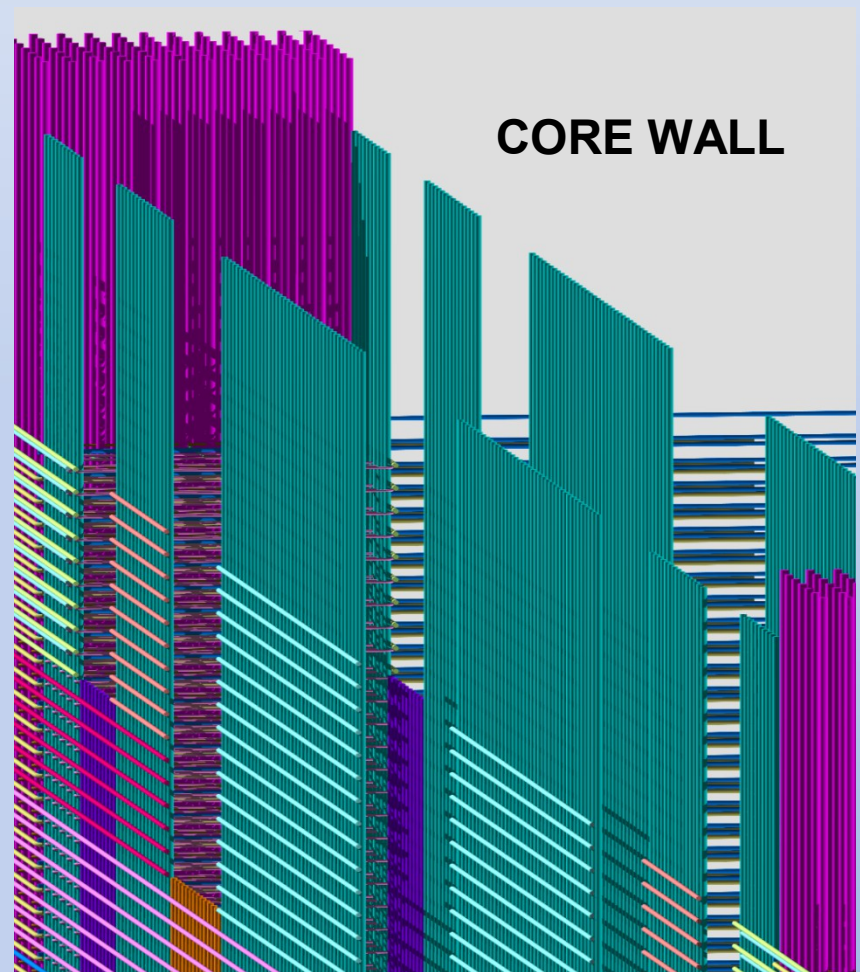
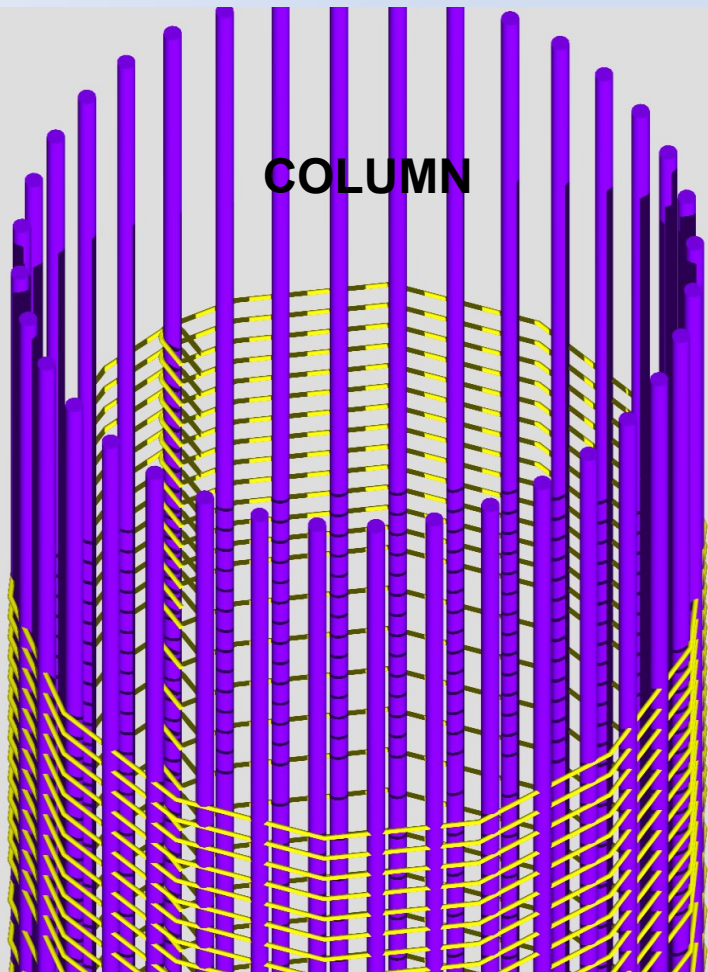

MODEL GENERATION

- REINFORCEMENT MODEL

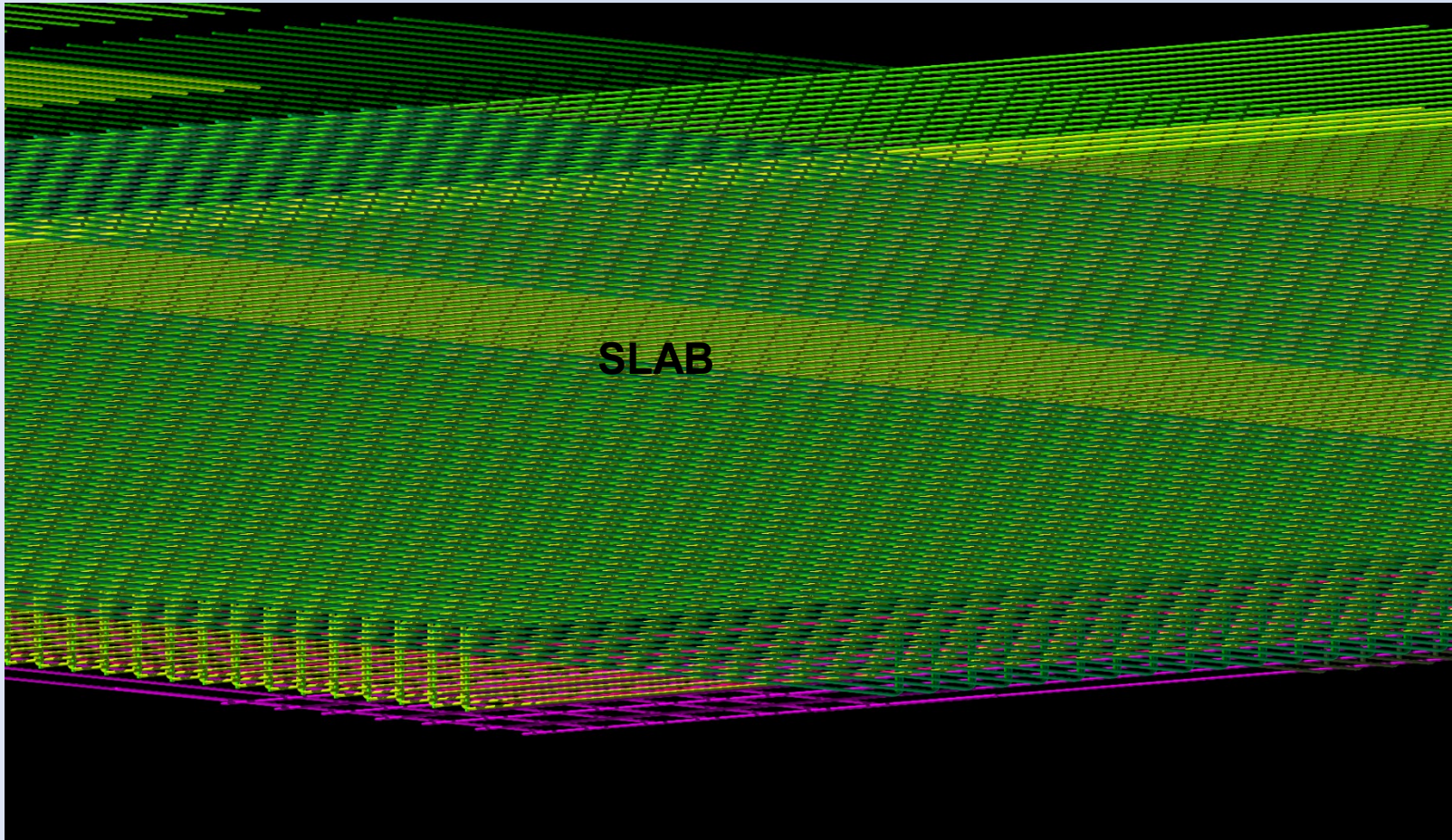

ANALYSIS & RESULTS

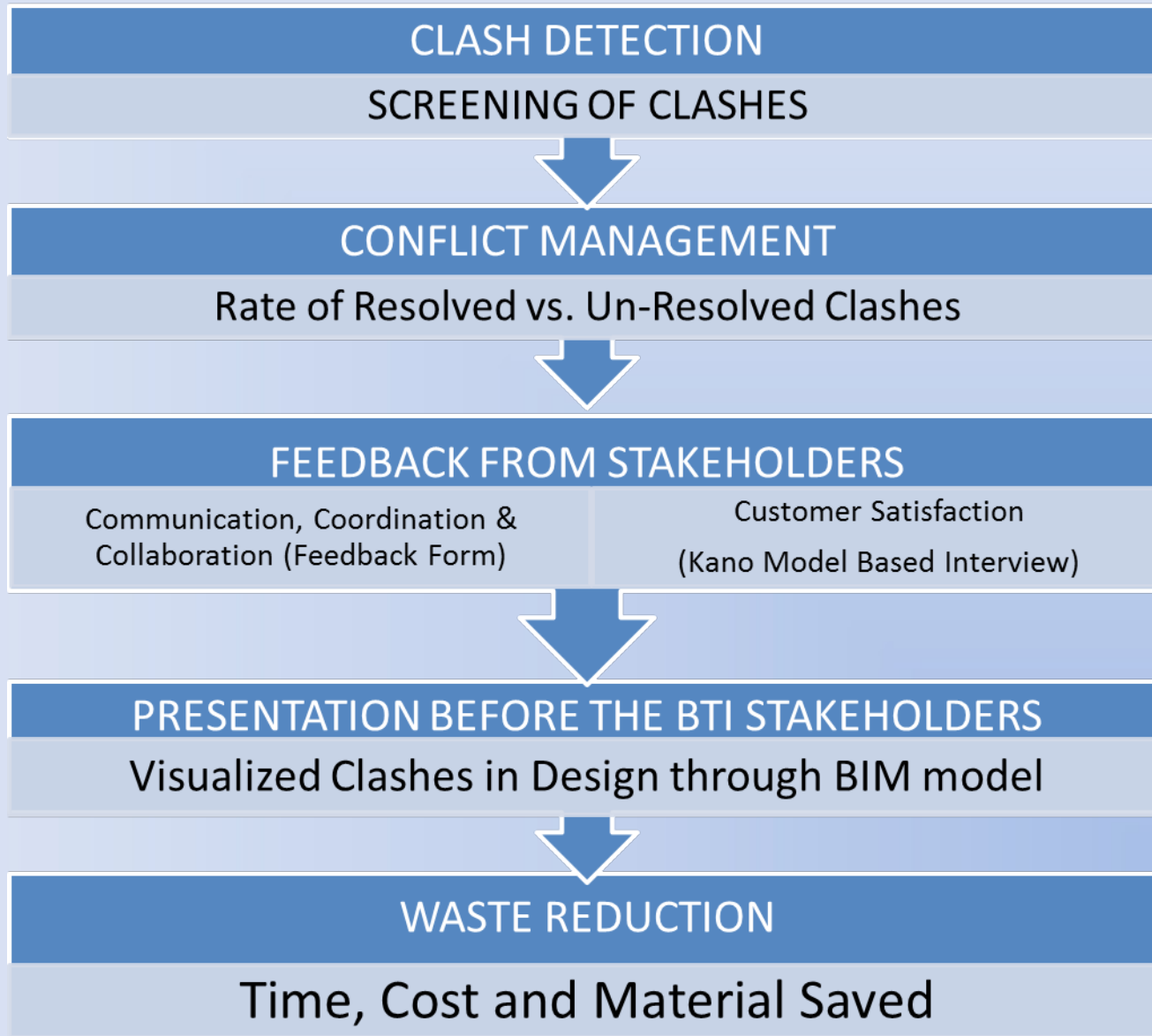

CLASH DETECTION

- Different 'sets' were made in order to find conflict against different elements
- These sets include:

ELEMENT	VS	ELEMENT
Beams		Slabs, Columns, Core wall, Outrigger
Slab		Exterior wall, Column, Core wall, Outrigger
Columns		Exterior Wall
Core wall		Outrigger

It was seen that **OUTRIGGERS** turned to be most critical area with maximum number of clashes with Corewall and Slab.

CLASHES SCREENING

- Screening is done on the basis of tolerance set.

Tolerance is measure of overlapping distance among clashed items

- On the following tolerance levels nature of clashes are classified as Major, Minor & Moderate

Tolerance	0mm	10mm	20mm
Nature of Clash	Minor (Resolved Clashes)	Moderate (Resolved Clashes)	Major (Unresolved Clashes)

OUTRIGGER (GIRDER) VS. COREWALL R/F

- Nature of Clash:
Major

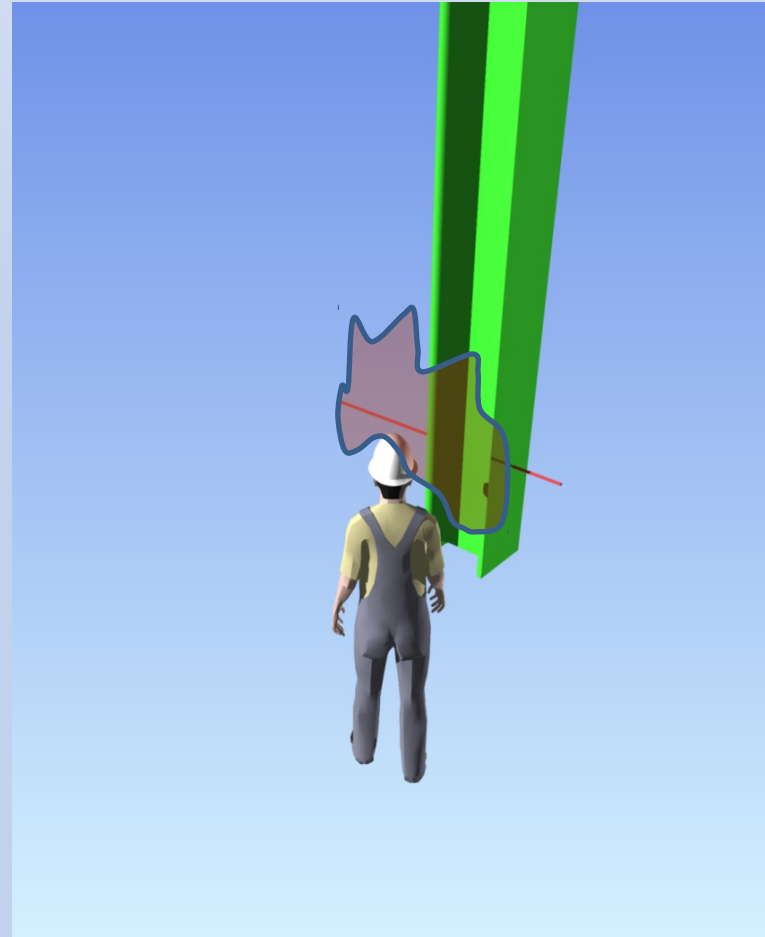

OUTRIGGER (SHEAR PLATE) VS CORE WALL R/F

- Nature of Clash:
Major

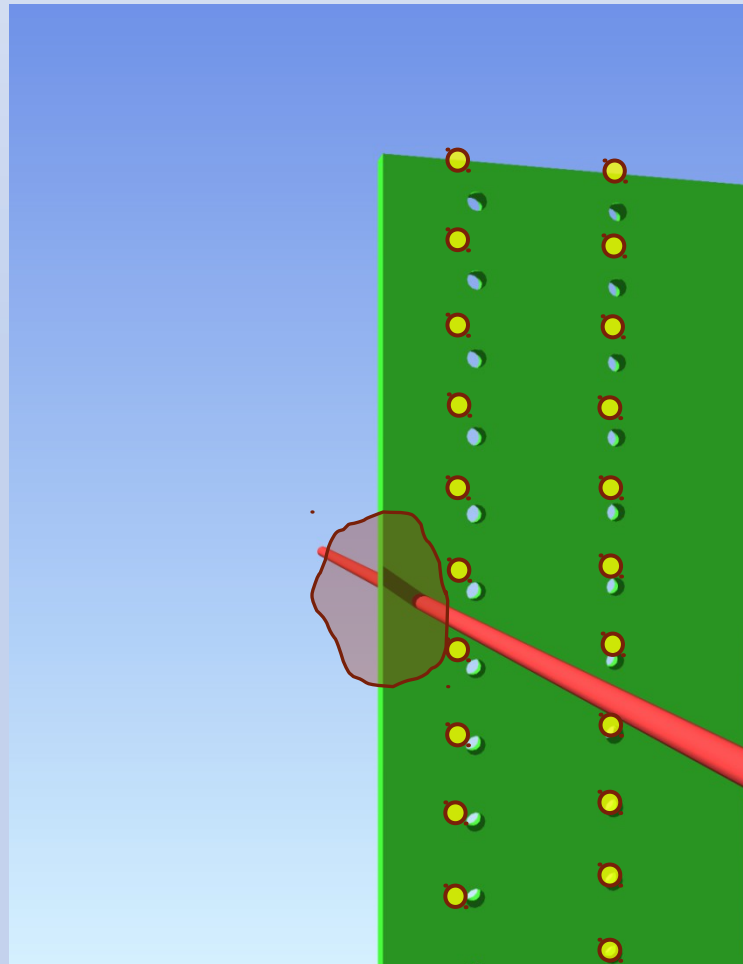

OUTRIGGER (GIRDER) VS COREWALL R/F

- Nature of Clash:
Major

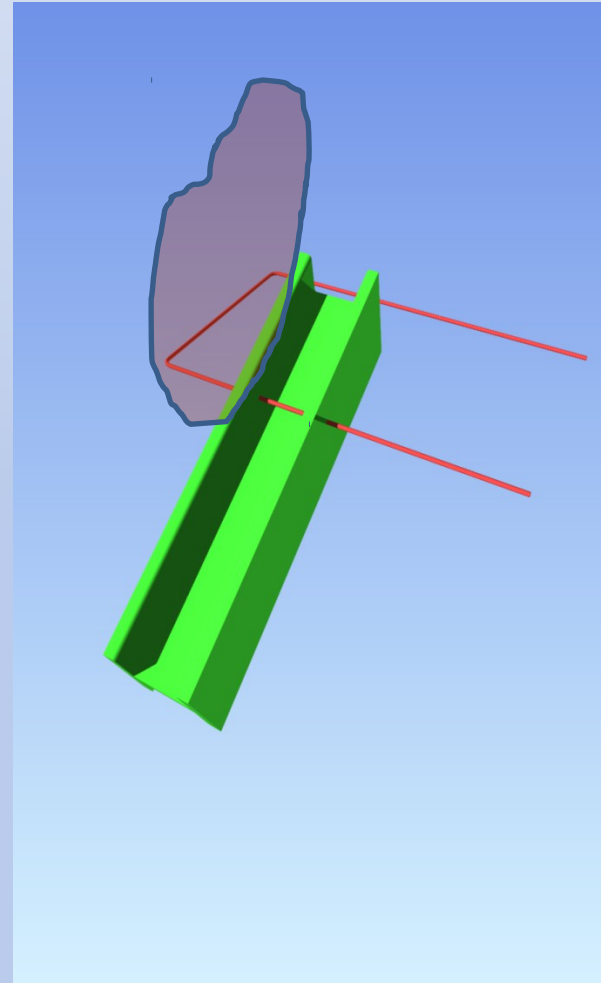

OUTRIGGER (STUDS) VS CORE WALL R/F

- Nature of Clash:
Moderate

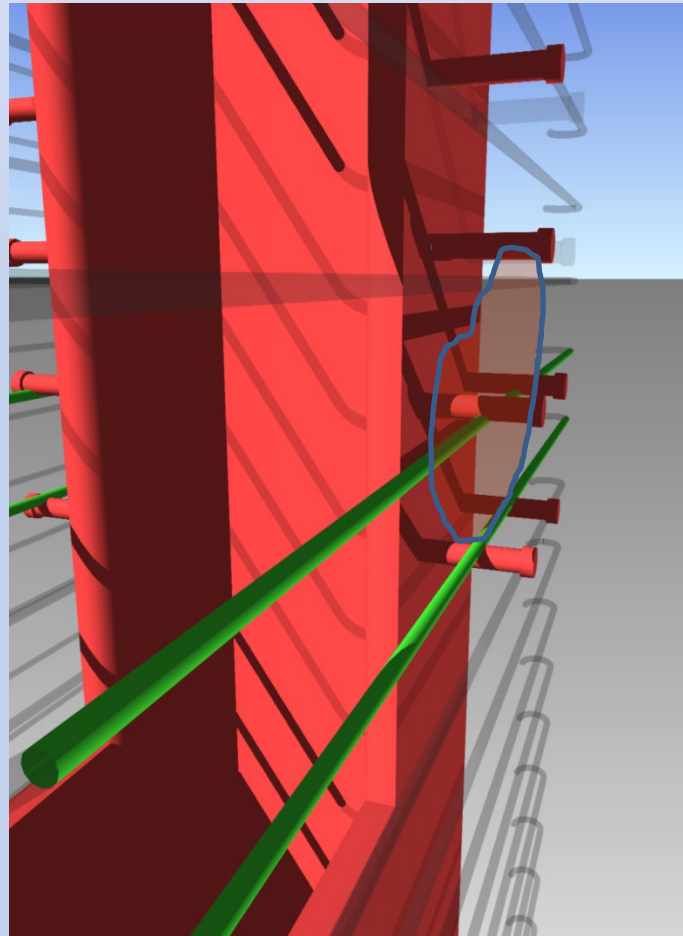

BEAM (STIRRUPS) VS SLAB R/F

- Nature of Clash:
Moderate

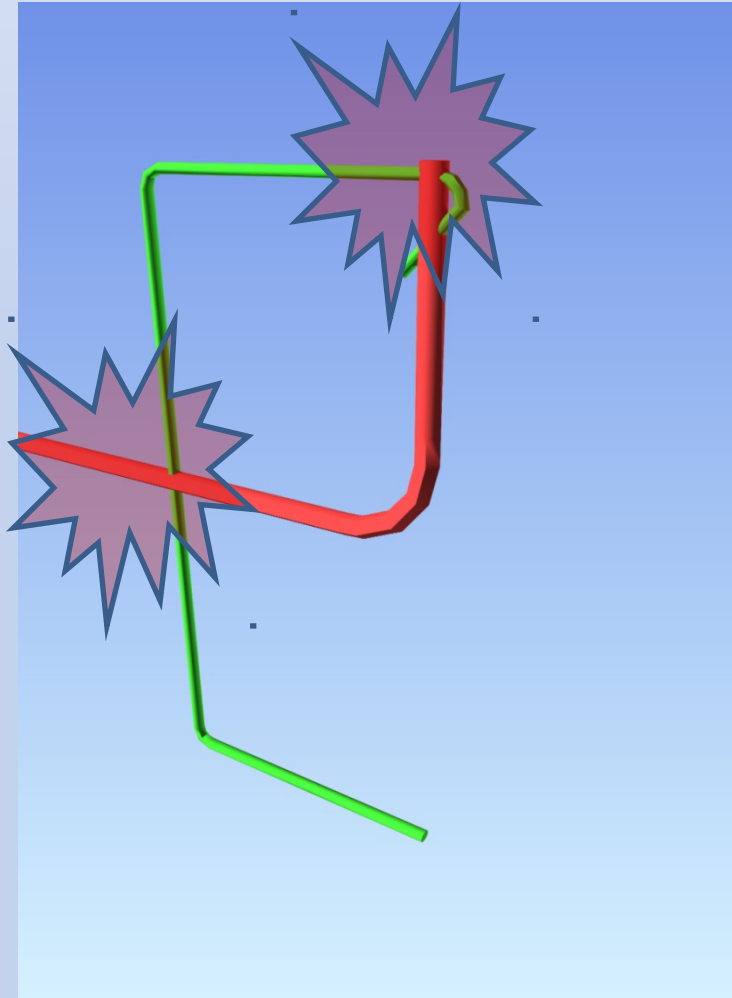

COLUMN (STIRRUP) VS EXTERIOR WALL R/F

- Nature of Clash:
Minor

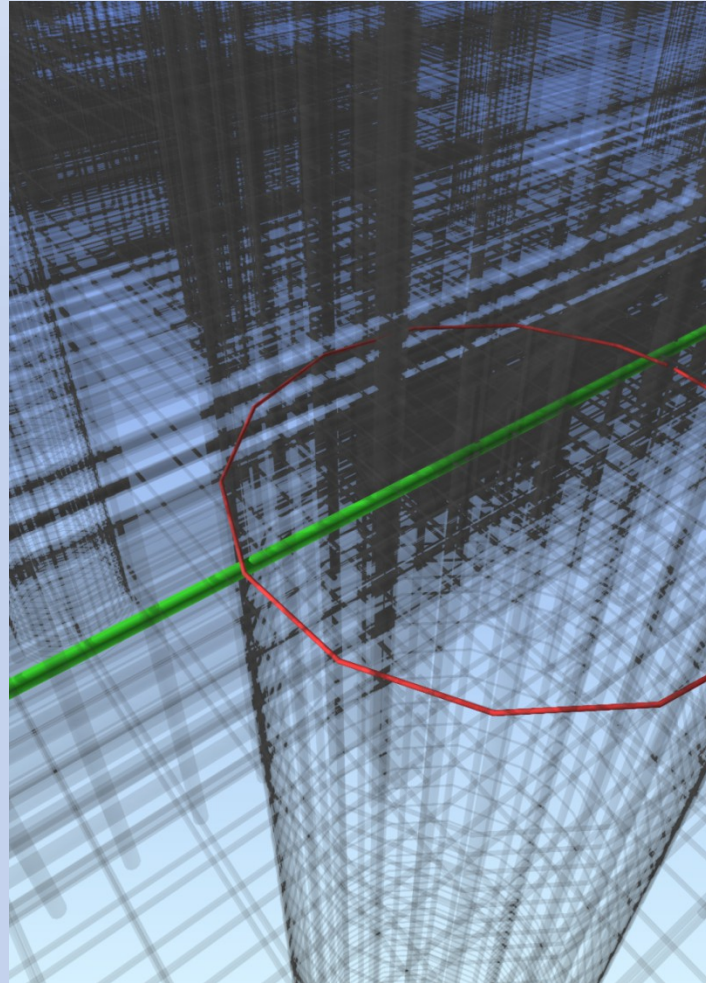

CONFLICT MANAGEMENT

- Resolved Clashes
- Un-resolved Clashes
- Rate of Conflicts Resolved/Managed =

$$\frac{\textit{No.of Clashes Resolved}}{\textit{No.of Clashes Detected}} \times 100$$

- Results:
 - Outrigger Reinforcement vs. Girders 0%
 - Outrigger vs. Column 84%

WASTE REDUCTION

- Major Clashes (at 20 mm Tolerance)
- Clashes among Outrigger, Core Wall and Slab.
- Three types of Waste
 - Time Lost (*days and cost*)
 - Labor Cost
 - Material Cost
- Results:
 - Total Cost Saved: Rs. 37,52869 (3.7 Million)
 - Material Cost: Rs. 25, 53556
 - Labor Cost: Rs. 1,17285
 - Time Saved: 3 days 7 hrs. Equivalent to Cost = Rs. 10, 82028

PRESENTATION AT BTI (Bahria Town Icon)

- BIM model and its clash analyses was presented to the BTI stakeholders at booking office of BTI.



At presentation stakeholders from client side, project managers, contractors, consultants, engineers, draftsman, and academicians.

CUSTOMER SATISFACTION

VALUE ATTRIBUTES	CUSTOMER SATISFACTION COEFFICIENT
COST REDUCTION	
Wastage Control	0.68
Resource Optimization	0.55
Time Management	0.83
PROCESS MANAGEMENT	
Improved Processes	0.60
Improved Efficiency	0.69
COMMUNICATION MANAGEMENT	
Better Visualization	0.84
Conflict Management	0.73
Improved Communication	0.66

COMMUNICATION, COORDINATION & COLLABORATION

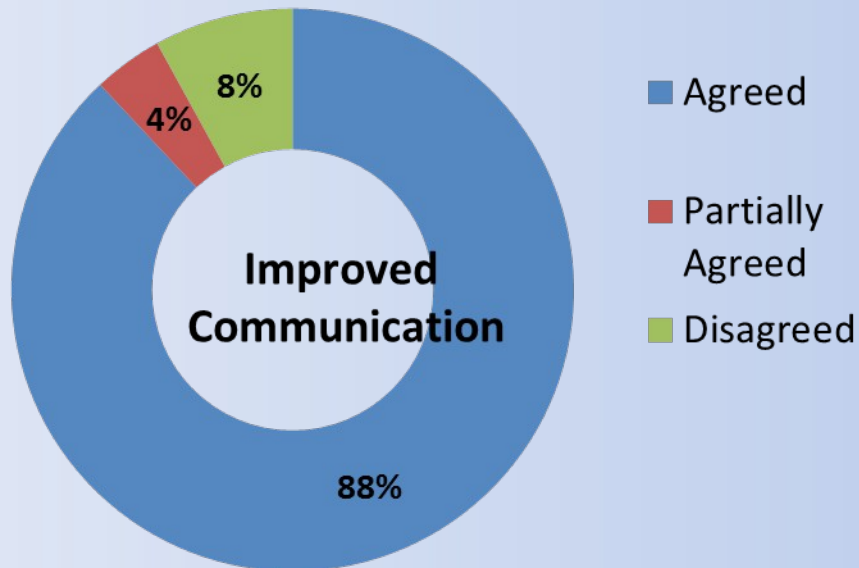
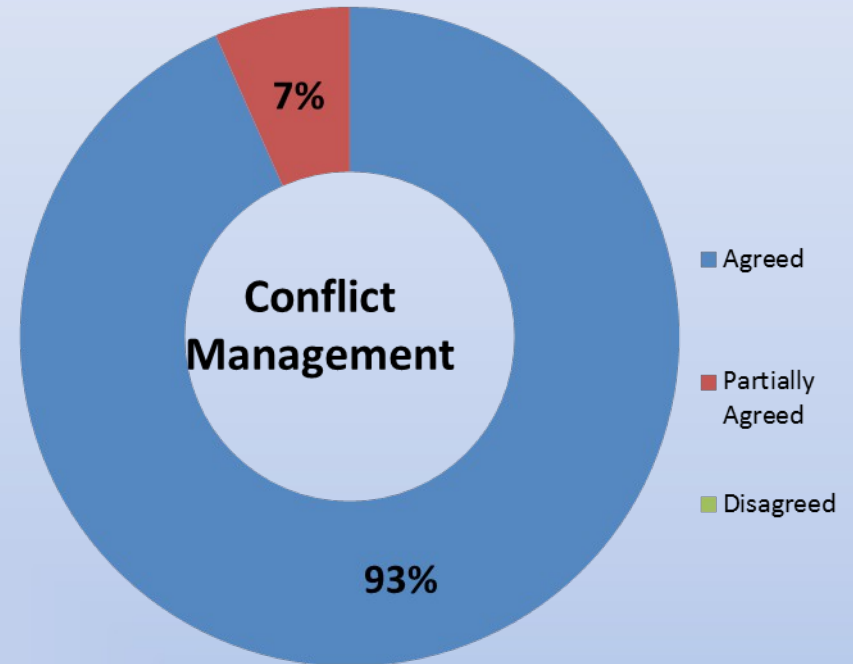
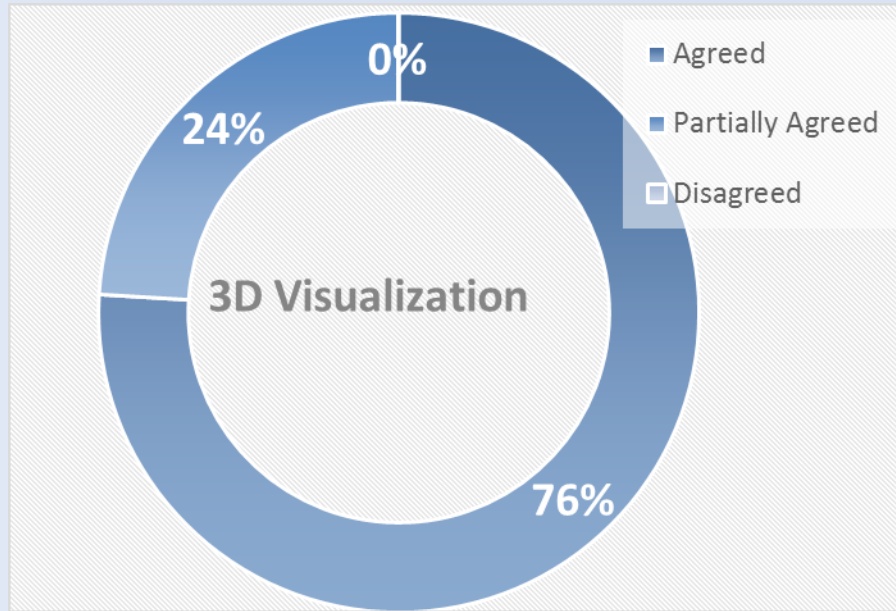

CONCLUSIONS

- **Rate of conflicts resolved for**
 - Core wall vs. Outrigger was 98%,
 - Outrigger vs. Column was 84%,
 - Outrigger vs. Slab 98%
 - Outrigger vs. Girder was 0 % and
 - these all were sent for query from the designer.
- **High CS-Coefficients relatively closer to 1 by time management and better visualization aspects of BIM model**
 - reflected a greater influence on Customer Satisfaction.

CONCLUSIONS

- **High percentage of more than 80% agreement on various aspects of Communication, Coordination & Collaboration was found**
 - to reflect effectiveness of BIM process on improving communication and coordination better.
- **Labor, time and material waste for the unresolved clashes was calculated.**
 - An overall cost of 3.75 Million PKR can be saved with the help of model..

RECOMMENDATIONS

Typical approach for an organization to adopt BIM will be to:

- Review your organization with objectivity, evaluate your company's position and capabilities,
 - And ask, “Is this organization set up to be successful with BIM?”

- Consider willingness of personnel to embrace a different type of project delivery and their tolerance for change.
 - Success with BIM has direct relationships with the participants' level of determination.

RECOMMENDATIONS

- **Study current archiving and document control methods in advance**
 - **And compare them with expected BIM deliverables**
- **Focus on the high-value returns of BIM for your business. Different project types and owners derive differing value from BIM.**
 - **For instance, an owner with internal maintenance and operations staff may value lifecycle uses of the BIM more than an owner who does not**

BIM Services

- MEP (Mechanical, Electrical, Plumbing) Services
- Architectural BIM
- Structural BIM
- Construction BIM
- HVAC BIM

Group Members

- ▮ **Nemar Zahid Anam** (UE-016)
- ▮ **Taha Khan** (UE-017)
- ▮ **Bilal Ali Khan** (UE-037)
- ▮ **Badar Ashraf** (UE-045)
- ▮ **Hafiz Usman Ahmed** (UE-064)
- ▮ **Sabeeh Zulfiqar** (UE-066)

Project Supervisors

- **Prof. Rizwan-ul-Haq Farooqui**
(Internal Supervisor)
- **Mr. Mohammad Umer**
(Co-Supervisor)
- ▮ **Syed Mohammad Ali**
(External Supervisor)

Any Questions?



THANK
YOU

